

CHP3



Family features:

- ▶ Double-Hall sensor available
- ▶ Degree of protection: IP 23
- ▶ Operation mode: S2/S3
- ▶ Direction of rotation: CCW/CW

| Voltage | Part number | P _n (Nominal power) | I _n (Nominal current) | n _n (Nominal speed) | M _n (Nominal torque) | M _a (Stall torque) | Gear ratio | Signal | Side* | Dimensional drawing (D) | Wiring diagram (W) | Drive end (S) | Connector (C) | Performance curve (P) |
|---------|---------------|-----------------------------------|-------------------------------------|-----------------------------------|------------------------------------|----------------------------------|------------|--------|-------|-------------------------|--------------------|---------------|---------------|-----------------------|
| | | W | A | rpm | Nm | Nm | | Hall | | | | | | |
| 24 V | F 006 B20 410 | 20.8 | 3.75 | 55 | 5 | 32 | 88:1 | 2x | R | D1 | W2 | S1 | C1 | P1 |
| | F 006 B20 411 | 20.8 | 3.75 | 55 | 5 | 32 | 88:1 | No | R | D1 | W1 | S1 | C2 | P1 |
| | F 006 B20 412 | 20.8 | 3.75 | 55 | 5 | 32 | 88:1 | 2x | L | D2 | W2 | S1 | C1 | P1 |
| | F 006 B20 413 | 20.8 | 3.75 | 55 | 5 | 32 | 88:1 | No | L | D2 | W1 | S1 | C2 | P1 |

*Gear housing left: L, gear housing right: R

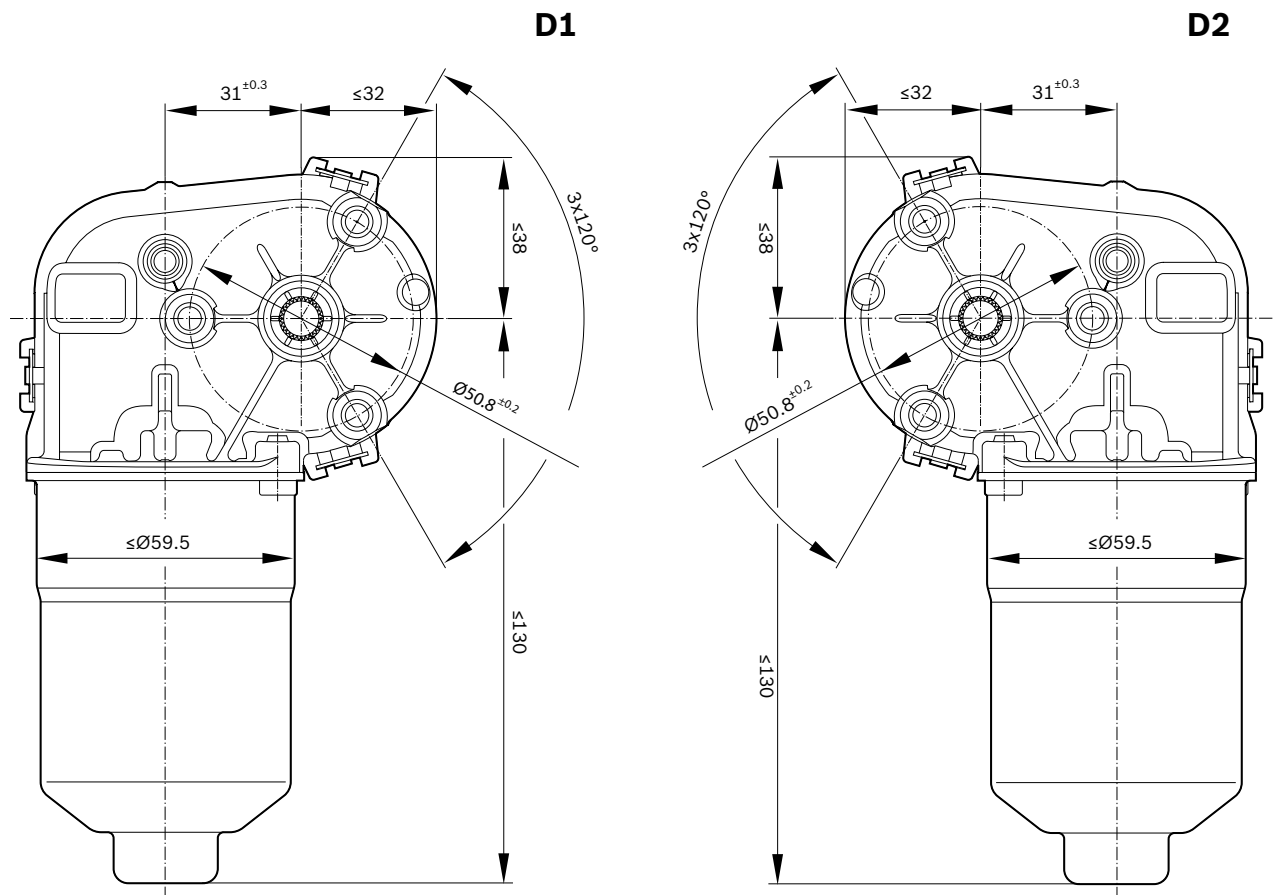

CHP3

Wiring diagram (W)

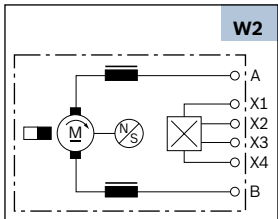
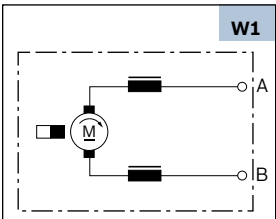

Performance curve (P)

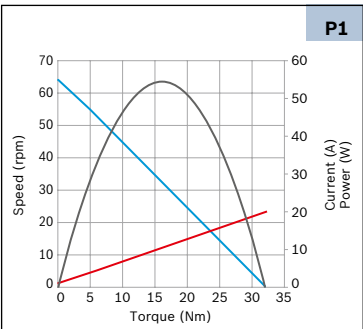

Drive end (S)

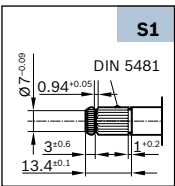

Mating connector (C)

