

# AHC-RS2

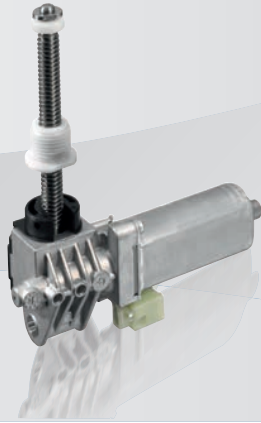

## Family features:

- ▶ Hall Sensor available
- ▶ Degree of protection: IP 50
- ▶ Operation mode: S2 - S3
- ▶ Linear movement

Voltage	Part number	$I_n$ (Nominal current)	$F_n$ (Nominal force)	$F_{max}$ Maximum force	Adjustment speed	Stroke	Signal	Dimensional drawing (D)	Wiring diagram (W)	Connector (C)	Performance curve (P)
		A	kN	kN	mm/s	mm	Hall				
12 V	0 390 203 693	10	0.4	1.95	15	48.9	Yes	D1	W1	C1	P1
	0 390 203 694	8	0.4	2.07	13	101.5	Yes	D2	W1	C1	P2

**D1**

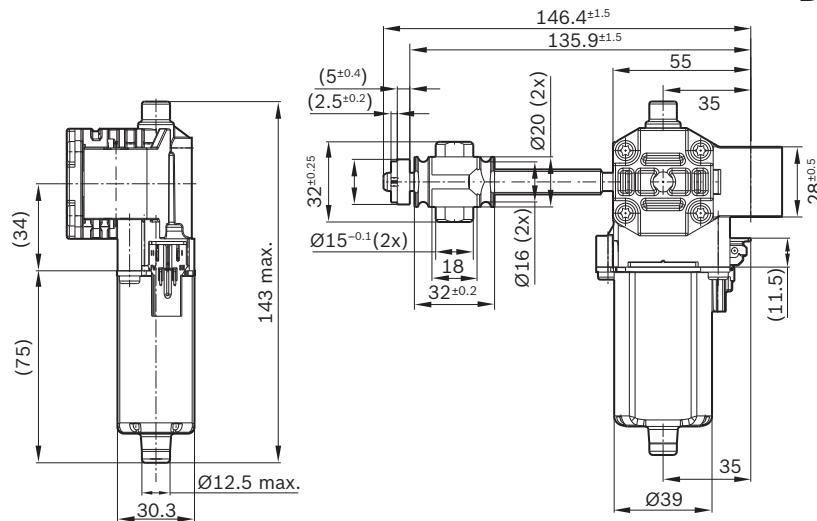

**D2**

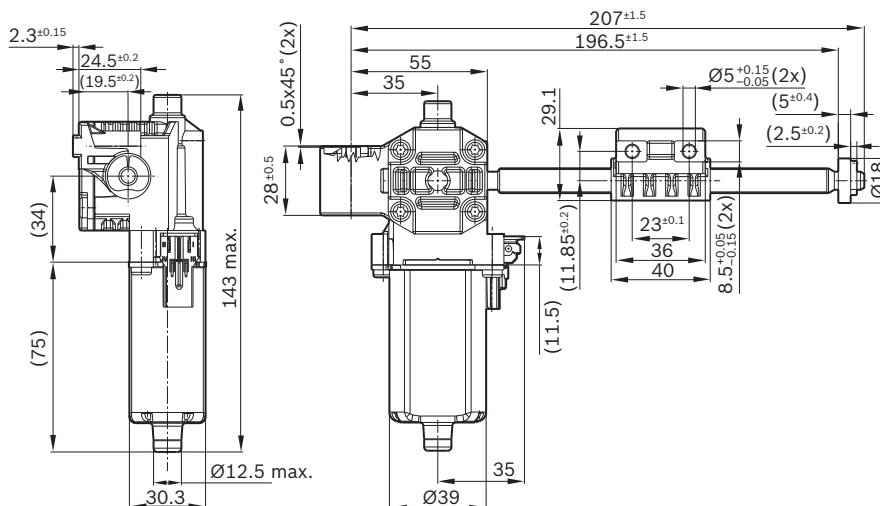

# AHC-RS2

## Wiring diagram (W)

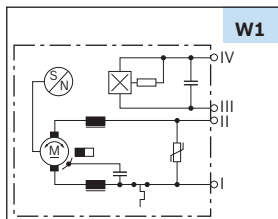

## Mating connector (C)



## Performance curve (P)

