

Diese Zeichnung ist unser geistiges Eigentum und darf ohne unsere Ermächtigung weder kopiert, vervielfältigt noch Dritten oder Konkurrenzfirmen zugänglich gemacht werden. ( Art. 12 B.G.)  
 This drawing is copyright. Information contained thereon is supplied in confidence and must not be used for any other purpose than which it was supplied, or be reproduced without written permission of the owners.

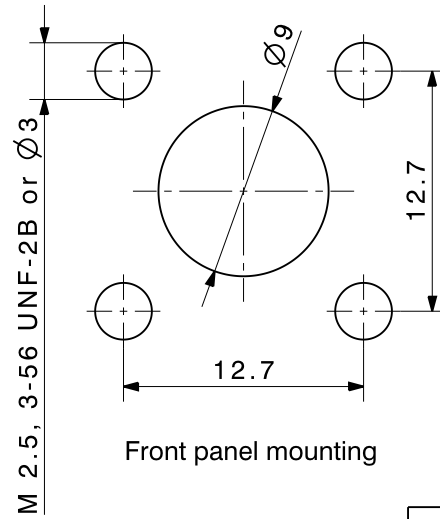

Mounting hole ML 106

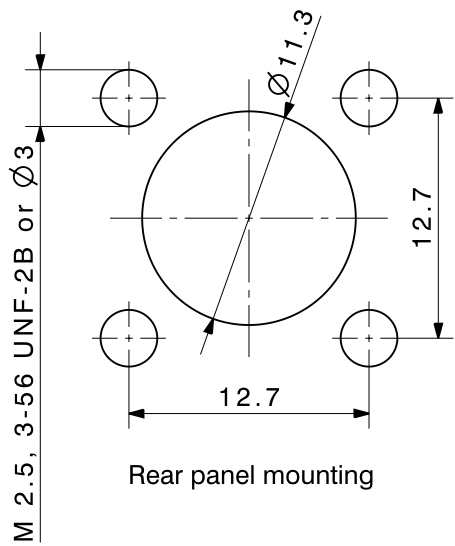
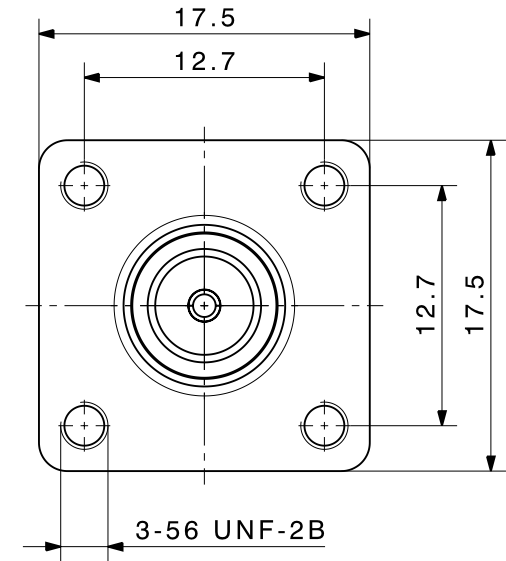
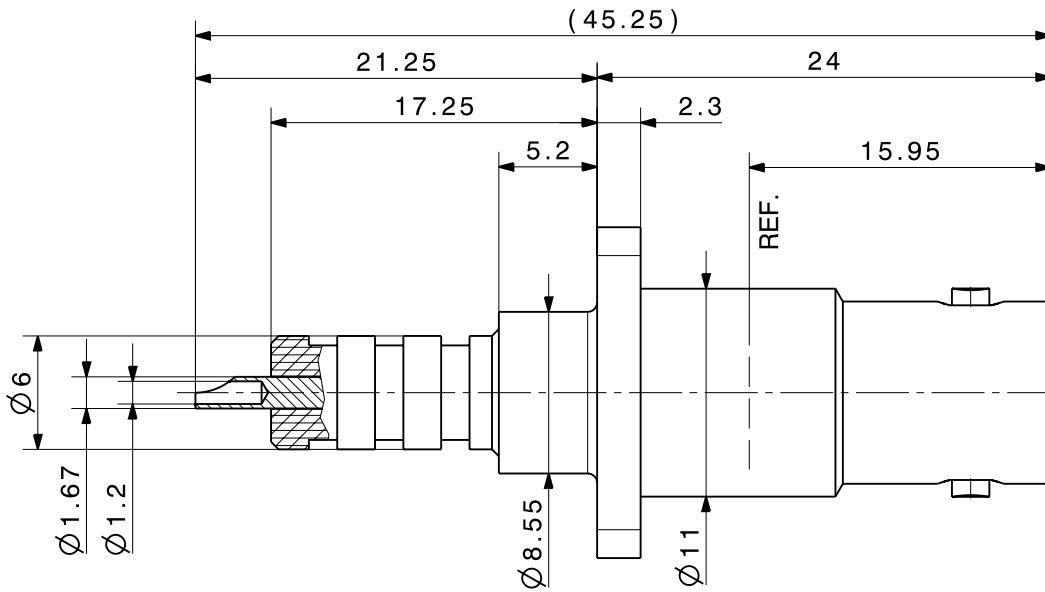
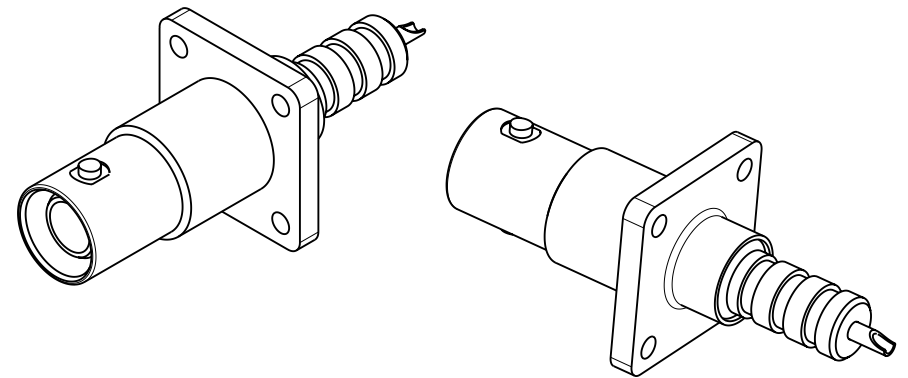

type / Typ: 23_SHV-50-0-1		part no. / Teile Nr.: PRO-00068551		B sheet/Blatt XX / XX	
⊕ dimensions in millimeter [mm]		description / Beschreibung		drawing-no. / Zeichnungsnr.	
Panel jack		DOU-00068551		Release B	
alternative ID:					