

GPG-M



Family features:

- ▶ High durability and efficiency
- ▶ Degree of protection: IP 10
- ▶ Operation mode: S1
- ▶ Direction of rotation: CW

	Part number	P _n (Nominal power)	I _n (Nominal current)	n _n (Nominal speed)	M _n (Nominal torque)	M _a (Stall torque)	Signal	Dimensional drawing (D)	Wiring diagram (W)	Drive end (S)	Connector (C)	Performance curve (P)
		W	A	rpm	Ncm	Ncm	Hall					
12 V	3 137 230 005	113	13	2700	40	330	No	D1	W1	S1	C1	P1
	3 137 230 006	134	15	3200	40	350	No	D1	W1	S1	C1	P2

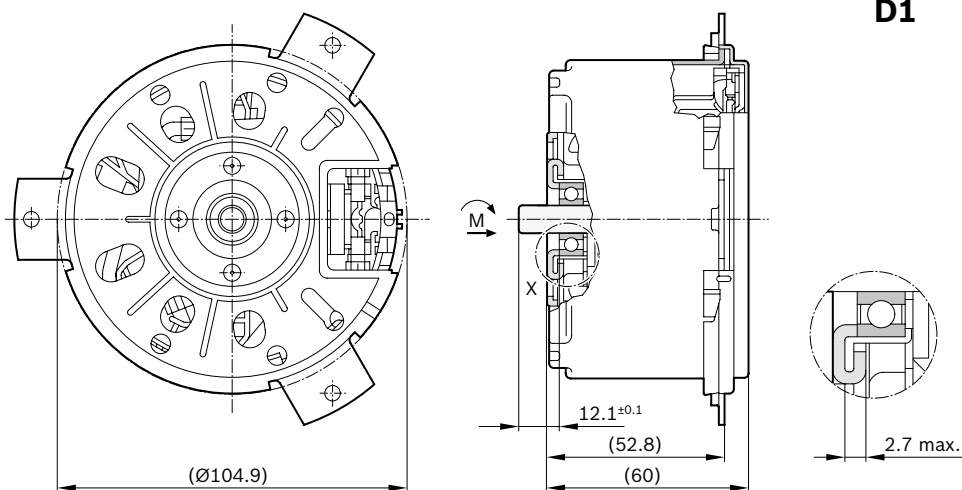

GPG-M

Wiring diagram (W)

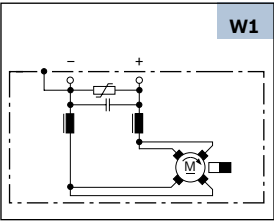

Drive end (S)

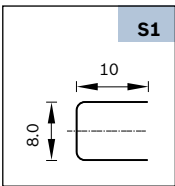

Performance curve (P)

